

## Membrane Switch Design Guide

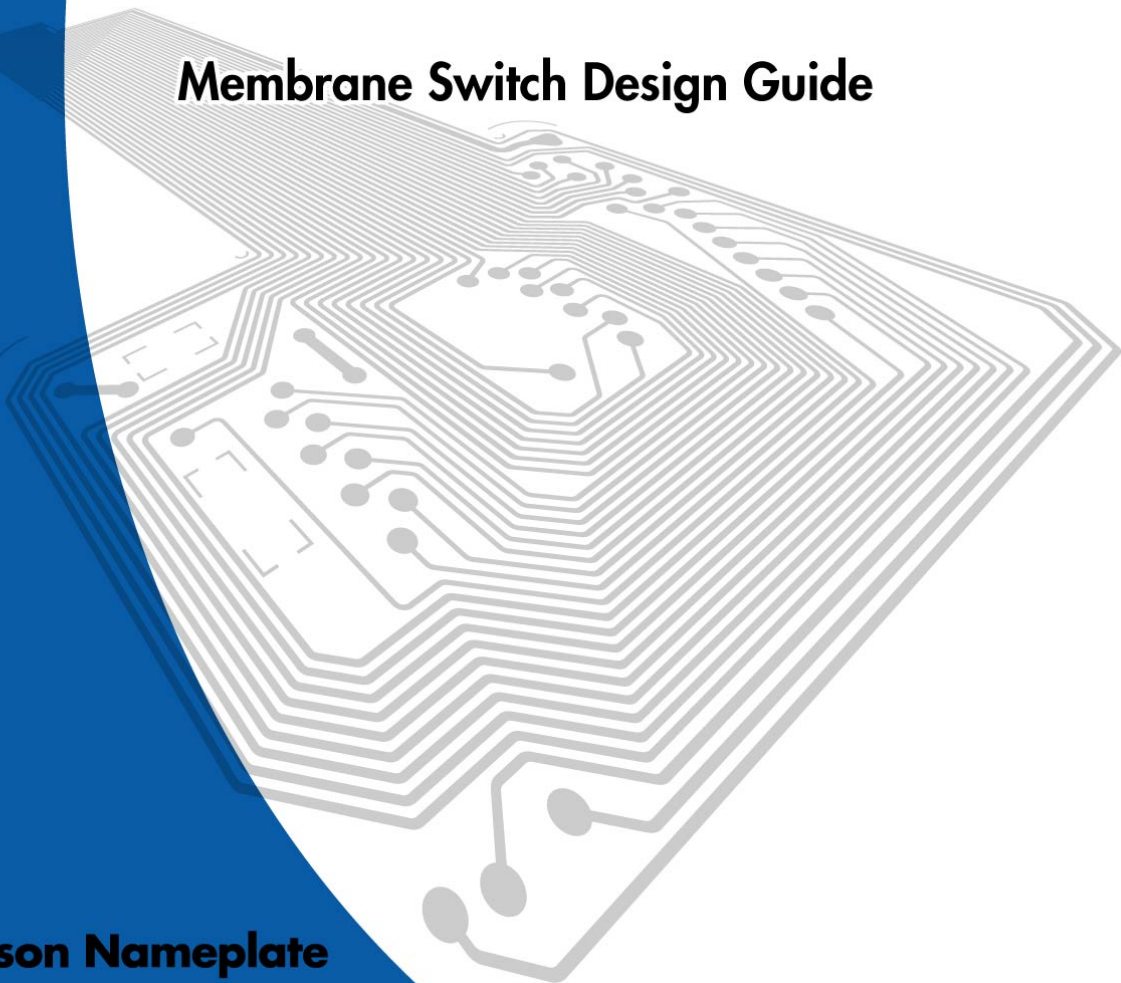

**Nelson Nameplate**

## CONTENTS

	PAGE
INTRODUCTION	2
OVERLAY MATERIALS	2
ARTWORK	2
COLOR MATCHING	2
ULTRAVIOLET HARDCOATS	3
EMBOSSING	3
COSMETIC INSPECTION	3
MECHANICAL TOLERANCES	3
LASER CUTTING	4
PINOUTS	4
ESD/RFI SHIELDING	4
TAIL EXIT POINT	4
INTERCONNECT	4
SCREEN PRINTED FLEX CIRCUITS	5
CREASING OF FLEX CIRCUITS	5
RIGID MEMBRANE SWITCHES	5
DURASWITCH TECHNOLOGIES	5
DOMES	5
ACTUATION FORCE	6
ELECTRICAL PERFORMANCE	6
LOOP RESISTANCE	
OPEN CIRCUIT RESISTANCE	
CONTACT RATING	
MAXIMUM LOAD	
CONTACT BOUNCE	
OPERATING TEMPERATURE	
LIFE CYCLE TESTING	6
WINDOWS	6
INSERTABLE LEGENDS	6
EMBEDDED LEDs	7
MOUNTING ADHESIVES	7
SUBPANELS	7
BACKLIGHTING	7
DRAWINGS AND SPECIFICATIONS	7

## APPENDICES

- A - PRICING CONSIDERATIONS
  - STANDARD CONSTRUCTIONS
- B - OVERLAY MATERIAL GUIDE
- C - SAMPLE DRAWINGS
- D - MEMBRANE SWITCH CHECKLIST
- E - REQUEST FOR QUOTATION WORKSHEET

**INTRODUCTION:** Membrane switch technology is a highly reliable interface solution with many advantages. The sealed nature of the overlays makes membrane switch technology an excellent front panel solution where environmental concerns are an issue.

The success of any membrane switch design effort is facilitated by effective communication between the design engineers and the vendor. This design guide is intended as an outline for communicating the requirements of our customers to Nelson Nameplate Company. A mutual understanding of the technology is very beneficial. Nelson Nameplate Company's engineers are equipped to help you design a switch that will meet all of your requirements.

**OVERLAY MATERIALS:** A variety of overlay materials are used in membrane switch applications. The most commonly used base material is polyester.

Polyester is a material that has superior life cycle and chemical resistance properties in comparison to other flexible materials. In life cycle testing, polyester shows no signs of wear at 1,000,000 cycles.

At one time, polycarbonate offered pricing advantages. Polycarbonate is still used for certain applications, however, the life cycle data shows that it begins to crack as early as 40,000 cycles. For this reason, Nelson recommends the use of polyesters in most applications.

Both polyester and polycarbonate are available with a variety of textures and hardcoats. In their uncoated, glossy form both materials are very susceptible to scratching. For this reason gloss materials should always be hardcoated.

Specialty materials have also been developed that offer some of the benefits of both polyester and polycarbonate. Outlined in Appendix B are the most commonly specified materials with a summary of their properties. Contact your Nelson sales engineer for additional technical data on any of these materials or visit our website:

[http://www.nelsonusa.com/membrane\\_switches/materials\\_components.htm](http://www.nelsonusa.com/membrane_switches/materials_components.htm)

**ARTWORK:** Most customers supply an electronic file in .ai (Adobe Illustrator), .cdr (Corel Draw) or other vectored graphics program. However, Nelson offers complete artwork layout services if required. The customer should specify type styles, colors, and sizes of all copy. Artwork should be provided to us for any logos or special symbols.

**DRAWINGS:** We use the latest version of Autocad to generate our drawings and artwork. It is helpful for customers to supply us with an Autocad DWG file, or as an alternate, a DXF or IGES file for mechanical dimensions. We can convert other files, including Macintosh, if necessary. It is always a good idea to provide Nelson with a hard copy of a drawing if a conversion is necessary.

The artwork will be plotted at Nelson on our 2000 dot per inch photoplotter that is capable of holding plus or minus .0005" tolerances over a 20" X 26" area. Proofs of the artwork will be sent to our customer prior to production.

**COLOR MATCHING:** There are many systems that a customer can use to communicate color requirements to us.

Pantone Matching System (PMS) is the most popular color standard. It identifies colors by specific numbers. This system was originally devised for use in the offset printing industry but has become a common tool for all types of printing. The Pantone System is very popular because it is inexpensive and simple to use. There are over 1000 colors displayed in a Pantone color guide that can be purchased for less than \$90.

The disadvantage of this system is that there are slight variations in the colors from sample book to sample book. The colors also fade with time, and books need to be replaced annually. These samples are printed with offset inks on white paper, and therefore we may not be able to exactly match a color by screen printing or painting on a particular substrate.

The Munsell Color System identifies colors in terms of three attributes: hue, value, and chroma. The physical samples to which we match using this systems are opaque, pigmented films. There are over 1500 Munsell color samples available. Nelson's files contain many, but not all, of these color samples. We

are able to order samples for colors we do not have on file.

Federal Standard No. 595a is used by the U. S. Government in its specifications. This standard has a limited number of color samples with varying gloss levels. We have samples for all 595a colors at Nelson.

CIE (International Committee on Illumination): The CIELAB color system is the most widely recognized system for describing colors with numbers. The advantage of using a numeric system is that it is objective, and computers can be used to match colors and quantify the closeness of a color match. We require a physical color chip (2" X 2" minimum) as well as the numeric color coordinates to match a color using this system.

Customer supplied color samples: We can match the color of a customer supplied sample if required. Our preference is that the sample be at least 2" X 2" on painted metal. The sample should also be opaque. It should be kept in mind that colors will appear different when printed on different substrates. This is especially true in the case of subsurface printing on membrane switch overlays.

Color samples are supplied to customers when requested. We supply a sample of the actual ink to be used in production applied to the same substrate from which the part will be made.

**ULTRAVIOLET HARDCOATS:** The most durable hardcoats are those that are cured by exposure to ultraviolet light. These coatings are called UV hardcoats. Nelson's proprietary coatings are called "Neltex". Neltex hard coats are applied through screen printing. Consequently, they can be deposited in selective areas. This is useful in creating coatings for windows, as well as enhancing graphics through the use of texture.

Another important aspect of "Neltex" hardcoats is that they are cured in an nitrogen environment. Because nitrogen does not react with the coating chemistries as oxygen does, Neltex hardcoats are harder than air-cured hardcoats. In the absence of oxygen more polymers bond to other polymers instead of oxygen.

Many times overlay materials are used that come with a hardcoat on them. Neltex hardcoats can be selectively added to many of the materials to produce parts with a velvet textured background, and gloss or anti-glare windows. Refer to the section on windows for more specific recommendations regarding window texture.

**EMBOSSING:** In many applications it is desirable to emboss or hydroform the keys of a switch. The phrase "Plateau Embossing" is used to describe keys that are raised and flat on the top. "Rim Embossing" is used to describe only the border of a key being raised. Embossing is typically .010" high and two dimensional.

Embossing example:



Hydroforming can be used to attain higher embossments, up to 2-3 times material thickness. Three dimensional dies can also be built. Overlays can be hydroformed with domes in them to provide tactile feedback. Hydroforming tools are significantly more expensive than embossing tools.

Hydroforming example:



We have made samples of both hydroforming and embossing on polyester and polycarbonate that will help illustrate the different results that can be attained. Polyester has greater memory and consequently does not form as crisply as polycarbonate. Contact a Nelson sales engineer to request hydroforming and embossing samples.

**COSMETIC INSPECTION:** In evaluating the cosmetic attributes of a membrane switch, it is important that the vendor and the customer have a common understanding of how the part will be inspected, and what the criteria for evaluation will be. To facilitate this Nelson has developed a standard cosmetic inspection specification. In the absence of a customer specification we will use this standard. The Nelson Nameplate Company Cosmetic Inspection Standard is available for downloading at [www.nelsonusa.com/downloads/cosmetic\\_inspection.pdf](http://www.nelsonusa.com/downloads/cosmetic_inspection.pdf).

This standard is also useful in setting a standard format for specifying cosmetic inspection requirements. It is recommended that in cases where a customer desires to establish his own inspection criteria, the format of our specification be used.

The key requirements include; viewing time, viewing angle, viewing distance, and allowable defect sizes.

**MECHANICAL TOLERANCES:** Steel rule dies are normally used to fabricate the various layers of

a membrane switch. Standard tolerances should be +/- .015". Tolerances of +/- .010" can be held on critical dimensions such as the perimeter or cutouts. Hole center to hole center tolerances of +/- .005" can be held. Tolerances on very large parts will be greater. Tighter tolerances can be held by laser cutting, or with the use of hard tooling if necessary.

The switch layers under the overlay will typically be fabricated smaller than the overlay. This allows for die cutting and assembly tolerances. All layers will typically be .015" inset from the overlay at all edges and cutouts.

**LASER CUTTING:** The various layers of a membrane switch can be cut out by using a numerically controlled laser. This technology offers two advantages. Tighter mechanical tolerances can be held, and no tooling is required. While laser cutting is a relatively expensive process, in many low volume applications it is cost effective. In most cases, if we are producing 100 parts or less, it is more cost effective to laser cut than to purchase steel rule dies.

**PINOUTS:** The schematic or pinout of a switch may be specified by the customer if necessary; however, as with any circuit layout, the more freedom we are allowed the more efficient layout we can produce. This has the advantage of shorter development time and a simpler circuit layout, which could affect switch cost.

Membrane switches can be designed with a common bus or in a matrix. Matrix layouts are desirable for keyboards with many keys to simplify the interconnect.

**ESD/RFI SHIELDING:** Several options are available for shielding membrane switches. The most common methods are printed carbon, printed silver, and aluminum foil. From a functional standpoint, the main difference among these materials is their conductivity. Both carbon and silver can be printed on the top side of the top circuit to act as a shield. Carbon shields are less expensive than silver shields. Silver is usually printed in a grid pattern to reduce cost. A foil shield has advantages both in conductivity and cost, particularly if the overall design does not need a printed top circuit. See Appendix A regarding economical design for additional information.

Another effective option for ESD shielding is a ground trace around the perimeter of the circuit layer. This adds very little cost and is often times effective for ESD shielding needs.

The shield can be connected to the ground through the connector, or by means of a tab with a slot that can be mechanically connected to ground. The interconnect should be noted on the print.

The customer should express their shielding requirements in units of Ohms per square inch if they are known. The entire product packaging must be considered when specifying shielding requirements.

It is important to know that the effectiveness of shielding is dependent on the entire membrane switch enclosure and end product features. We will use our experience to make recommendations during the initial design and work with you during testing if additional shielding is necessary.

**TAIL EXIT POINT:** Flexible membrane switches are connected by means of a flexible tail that is cut from the circuit material. We have a great deal of flexibility in selecting the exit point. The tail cannot exit under or within .125" of the active keypad area.

#### **INTERCONNECT:**

Note: Component data pages for interconnect options are available at:  
[www.nelsonusa.com/membrane\\_switches/materials/components.htm](http://www.nelsonusa.com/membrane_switches/materials/components.htm)

The flexible tail that exits a membrane switch usually has single row traces on .100" centers. This tail can be connected to a circuit board with many different single row connectors designed for flex circuits or can be designed to interface with a ZIF (Zero Insertion Force) connector. Nelson is tooled to crimp Nicomatic, AMP and Berg connectors onto flex circuits.

The lowest cost interconnect is a ZIF (Zero Insertion Force) connector. AMP and Molex both offer ZIF connectors. When using a ZIF connector the membrane switch is designed with exposed contacts on the end of the tail. The customer then inserts the tail into the ZIF connector. ZIF connectors are readily available with locking mechanisms in 1mm center versions. When using a ZIF connector you should specify either the specific connector, or the requirements for the connector.

The AMP system is a two component system. The contacts are specified separately from the housing. One critical consideration is the insulation displacement characteristics of the AMP system. If the design uses dual tails or insulation over the entire

contact area, we recommend the AMP connector system. Nelson engineering would be happy to help specify the best connector for your application. If necessary, a generic callout such as "Female Connector" can be added to the print until the design is finalized at Nelson.

Flex circuits may also be terminated with solder tabs that can be directly soldered onto the circuit board.

### **SCREEN PRINTED FLEX CIRCUITS:**

The typical flex circuits used in membrane switches are made with screen printed silver-filled epoxy ink. The process is carefully controlled to insure maximum conductivity, adhesion, and flexibility.

**CROSSOVERS:** Nelson has developed proprietary feed-through technology which creates double-sided circuits. This allows for more flexible designs when space is a constraint. Feed-throughs also offer an advantage in high humidity environments by minimizing the risk of silver migration. This technology does increase the number of printing operations, and may increase cost.

**CREASING OF FLEX CIRCUITS:** In many applications, the tail of a membrane switch needs to be bent at or near the exit point. Extreme caution should be exercised when bending flex circuits. Membrane switch tails should not be creased. While it is likely that continuity will be maintained in a trace that is creased sharply, the trace will most likely be damaged, and be a potential area of future failures

Always inform Nelson's Engineering Department when maximum flexibility is required in the tail of a membrane switch.

**RIGID MEMBRANE SWITCHES:** In some cases it is desirable to build a membrane switch onto a rigid circuit board instead of using screen printed flex circuits. This construction provides a rigid panel and allows for the easy addition of other components such as LEDs and resistors. These types of membrane switches are usually supplied with a standard header with pins on .100" centers.

**DURASWITCH TECHNOLOGY:** Nelson is a licensee of Duraswitch technology. Duraswitch technology includes PushGate, MagnaMouse and ThinRotor components.

Pushgate Switches: Duraswitch Pushgate switches are used as an alternative to stainless steel domes. They

consist of an armature used in conjunction with a magnetic layer. The armature breaks away from the magnet giving a distinctive tactile feel. The actuation force is approximately 10 ounces and is not adjustable. There are two sizes of Pushgate armatures. Several methods exist for incorporating Pushgate switches into a design. Due to the special nature of these components, a Nelson Sales Engineer should be consulted.

MagnaMouse: The Duraswitch MagnaMouse armature is similar to a Pushgate switch as it is comprised of a stamped metal unit that breaks away from a magnetic layer. The MagnaMouse is approximately 1" in diameter and uses a center pivot. By printing various circuitry patterns on a flexible substrate, compass coordinates can be created. There can be as few as four directions or as many as eight. There has been special software created to aid the use of the MagnaMouse that is available directly from the software developer.

ThinRotor RT: The Duraswitch ThinRotor is a surface mounted rotary switch. Using rare earth magnets that are housed in a specially developed rotary mechanism, conductive balls are pulled from the opposite side of a printed flexible circuit. The design is such that there are no holes in the flexible substrate and due to the printed side facing away from the overlay the design is innately sealed. The most successful uses of the ThinRotor are in those applications where there is little to no room behind the user interface area.

Nelson's Sales Engineers should be consulted early in the design cycle as there are special thickness and design considerations when using Duraswitch Technology.

**DOMES:** Because of the relatively short travel of membrane switches, it is often necessary to provide users with some type of feedback. Feedback can be visual, audible, or tactile. Visual or audible feedback should be a consideration in the electronics design.

Domes can be added to a membrane switch to provide tactile feedback. There are two types of domes that we use in membrane switches, stainless steel and polyester. There is no significant difference in reliability between these two dome technologies.

Many people prefer the feel of stainless steel domes. Stainless steel domes also require lower initial tooling costs. Stainless steel domes are almost always used on printed circuit board based membrane switches.

Polyester domes are usually formed into the top circuit of the membrane switch. Polyester domes require relatively expensive machined tools that are built specifically for each design. As volumes increase, polyester domes become more cost effective because they do not need to be assembled individually. As a general rule of thumb, it makes economic sense to consider polyester domes if the total dome usage per order is expected to exceed 1500. This is also dependent on the density of the domes in relation to the size of the overall switch. Higher density usually results in a better fit for a Polydome design. Polyester domes relax and lose their tactile feel at elevated temperatures. Polyester domes are not recommended for applications that will experience temperatures above 55°C (131°F).

**ACTUATION FORCE:** The customer may specify switch actuation force. Typical actuation forces range from 6 to 24 ounces. Polyester domes usually have greater actuation force than do stainless steel domes. Polyester domes have typical actuation forces of 14 to 24 ounces. Stainless steel domes are in the 12 to 18 ounce range. The tolerance on actuation force is +/- 3 ounces.

**ELECTRICAL PERFORMANCE**

The great variety of membrane switch designs make it difficult to outline a general set of specifications that covers all membrane switches. Listed below are some basic performance specifications. If an application has specific requirements, then these must be communicated to Nelson.

**LOOP RESISTANCE:** The loop resistance of a switch is a function of trace width and length. In most applications the maximum loop resistance is less than 100 Ohms.

**OPEN CIRCUIT RESISTANCE:** 50 MegaOhms minimum

**CONTACT RATING:** 100 Milliamps at 28 VDC Maximum

**MAXIMUM LOAD:** 1.5 VA Nominal

**CONTACT BOUNCE:** 5 Milliseconds Nominal

**OPERATING TEMPERATURE RANGE:** -20C to +75C (See notes on polyester domes)

**LIFE CYCLE TESTING:** Nelson has an ongoing program of life cycle testing to insure that all

of our switch designs will continue to function beyond 1,000,000 cycles. Many designs can be expected to last much longer. Any specific life requirements should be communicated to Nelson's engineering department before the design begins. Life cycle and environmental testing data pages are available on-line at [http://www.nelsonusa.com/membrane\\_switches/data\\_sheets.htm](http://www.nelsonusa.com/membrane_switches/data_sheets.htm)

**WINDOWS:** The overlay materials used in membrane switches begin the process clear. Colors are screen printed on the back of the overlay material. Areas that do not have color printed on them become windows.

As mentioned in the section on hardcoats, window areas can have a variety of hardcoats or textures added to them. It is recommended that small discrete LED enunciator windows have the same texture as the background.

Larger windows for LEDs, LCDs, or VFDs may need a window with less light diffusing characteristics. Window coatings in general are a trade-off between anti-glare characteristics and optical clarity. The closer the display is to the overlay the less effect the coating will have on display readability.

If LED displays are within .062" of the overlay, a velvet texture will usually yield acceptable readability. For distances greater than .062", we recommend a gloss or antiglare finish for the window coating.

If LCD displays are within .125" of the overlay, an anti-glare coating should yield acceptable readability. For distances greater than .125" a gloss coating may be necessary. Nelson has designed and printed samples of various materials and coatings to assist our customers in making well-informed decisions when specifying window designs. Contact your Nelson sales engineer and request a Material Selector Guide and a Neltex Sample Sheet.

**INSERTABLE LEGENDS:** In some applications it is desirable to have the ability to customize some of the legends, either when the switch is assembled to the end product, or in the field. This allows a customer to use one standard membrane switch for many different models of similar instruments. It also allows customizing a membrane switch for specific applications during the manufacturing process or by the end user. Successful applications have included vending machine flavors, multiple languages, and private labeling.

To design a switch with insertable legends, a clear window is put into the area that will have insertable legends. An oversized pocket is put behind this clear area so that the legend card can be inserted and viewed through the window. The entire overlay has the same texture, which helps disguise the fact that legends are being viewed through a window. The diffusing properties of the texture are not a problem for viewing the legends because the legend cards are held directly against the overlay by the pocket.

It is also recommended that the background color be different than the color surrounding the window. This will also help disguise the legend card. The fact that a membrane switch has insertable legends can be almost completely transparent to the user if implemented correctly.

**EMBEDDED LEDs:** It is common to include small surface mounted LEDs into membrane switches. This is a very simple way to add enunciators to a switch.

A standard membrane switch is not thick enough to accommodate the package size of most surface mounted LEDs. For this reason, the overlay may be embossed in the window area, or extra fillers may be added to the switch construction.

Silver conductive epoxies are used to mount the LEDs to the circuit. These epoxies are not very flexible. Nelson has a proprietary process where we bond the led to the circuit creating a very durable connection. As with any switch, care must be taken to not excessively bend the unit, however, Nelson's LED bonding process will allow for some bending.

Data sheets and engineering samples for embedded LEDs are available from Nelson sales engineers and at [www.nelsonusa.com/membrane\\_switches/design\\_samples.htm](http://www.nelsonusa.com/membrane_switches/design_samples.htm)

**MOUNTING ADHESIVES:** In most cases flexible membrane switches are shipped to our customers with a pressure sensitive adhesive on the back side. The most commonly used adhesive is 3M's 467MP. This is an excellent adhesive for bonding to smooth metal and high surface energy plastic surfaces. For rougher surfaces we recommend 3M's 468MP. Some surfaces such as powder coated surfaces have lower surface energy. There are specific adhesives that are more appropriate for low surface energy applications. We have many adhesives to assist in these applications. If you are uncertain as to the correct

adhesive for your mounting surface, contact a Nelson sales engineer.

Always clean the surface before installing a membrane switch. If alignment is difficult, we recommend that you remove a small corner of the backing, align the membrane switch, stick the corner down, bend back the membrane switch and remove the rest of the liner. NEVER bend a membrane switch in an LED or dome area. After the membrane switch is correctly located, rub it down with firm pressure. The adhesives we use are called pressure sensitive adhesives because they need pressure to insure a strong bond. The adhesive will continue to cure for many days. It will have reached 90 percent of its ultimate bond within 72 hours of installation under most conditions. No testing of the adhesive should be done within 72 hours of installation.

**SUB PANELS:** In some applications it is desirable to have Nelson supply the membrane switch mounted to a rigid sub panel. The most commonly used material for such sub panels is aluminum. Aluminum sub panels can be supplied with a variety of hardware installed. Other options include polycarbonate or acrylic backer panels. These can have chamfers or other features but normally do not use hardware.

It is important to keep in mind that the sub panel must have different mechanical dimensions to allow for assembly tolerances. The sub panel should be .020" smaller than the membrane switch in both height and width. All cutouts and holes should be .030" larger. Cutouts behind windows should be .060" larger than the window. These general guidelines are intended to help insure that the sub panel is not visible after assembly.

**BACKLIGHTING:** We offer several backlighting solutions for viewing legends in no light and low light applications. The most common backlighting methods used are Fiber Optics, Electroluminescent panels, and LEDs. Fiber Optics and Electroluminescent panels offer the advantage of uniform light over a large area. Nelson Engineering can assist in deciding which backlighting option is right for your design.

**DRAWINGS AND SPECIFICATIONS:** Our ability to manufacture a switch which meets our customer's expectations is dependent on how well we understand our customer's requirements. The customer should be sure to supply us with as much detail about

his design requirements as possible. A sample of a drawing of a membrane switch is included in Appendix "C".

Appendix "D" is a checklist of issues that should be addressed in communicating a customer's complete requirements. It is helpful for the customer to supply a copy of this checklist with notes on topics not covered elsewhere in his documentation.

## PRICING CONSIDERATIONS

As with any successful project, the more detailed the requirements, the better the chances a part will meet expectations. Nelson understands the limited time that most companies have for product development. We have assisted with many successful projects where only a graphic representation of the switch was available. Nelson is capable and willing to take these early ideas and help refine them into solid specifications. We encourage our customers and potential customers to contact Nelson early in the project for assistance.

### Pricing Considerations and Constructions:

There are many variables in the price of a membrane switch. The overall size, number of domes, construction type and artwork all play important roles in how the switch is designed and priced. The following is meant to assist you in planning but may not be accurate for your specific design.

- Unit pricing is volume dependent. The more parts ordered, the lower the unit cost.
- For Budgetary purposes, every printing pass adds approximately \$120.00 plus \$0.005 per square inch into the overall cost. (i.e. for a 5" X 5" part each color adds \$1.325 in the 100 unit cost, for a 18" x 4" part each additional color will add \$1.56 in the 100 unit cost)
- Most embossing dies (non-hydroforming) cost less than \$200.00. The embossing itself adds approximately \$0.30 to the 100-piece unit cost in a typical 5" x 6" design.
- Connector pricing and availability varies greatly. Connectors typically add \$1.00 - \$2.00 to the unit cost.
- The fewer the layers, the more cost effective the construction. There are several cost saving principles:
  - The most cost effective construction is a graphic layer with shorting pads over a single circuit with rear adhesive:

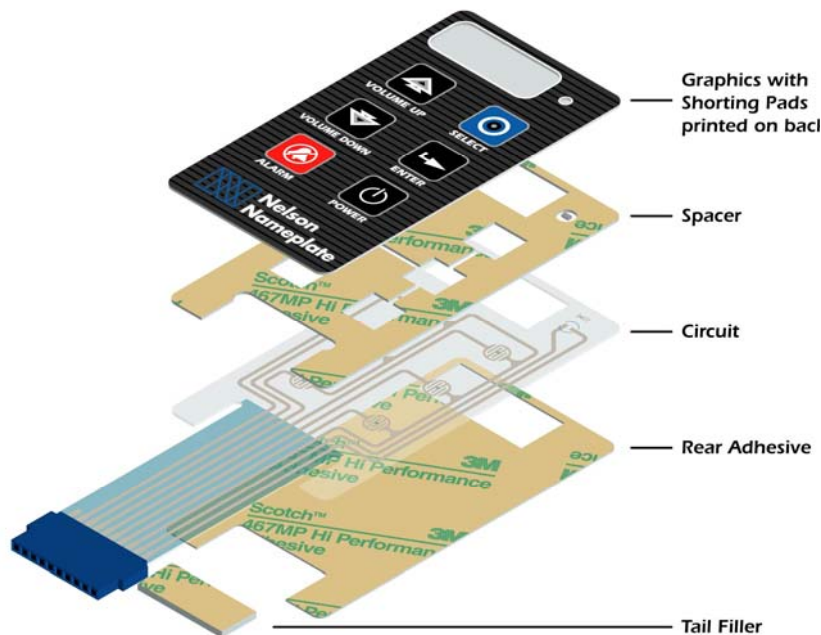

- Tactile feel can be added by forming a dome into the graphics. This is cost effective once the number of tactile domes exceeds 1500 in an order unless you have a large part with relatively few domes. The size of the part and the density of the domes play a key roll in this decision. If fewer domes are needed, stainless steel dome constructions may offer cost advantages.

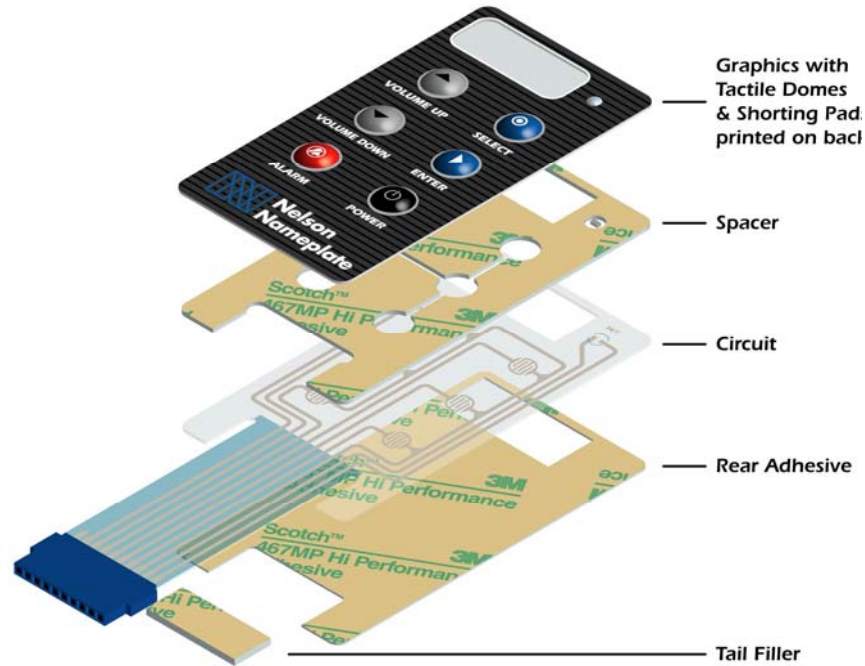

- Stainless Steel Dome construction:
  - Ideal for small quantities where tactile feel is necessary or where there is low dome density on large parts.
  - If the part is to be embossed, the embossing shape should be square and the same size as the dome cavity if possible.

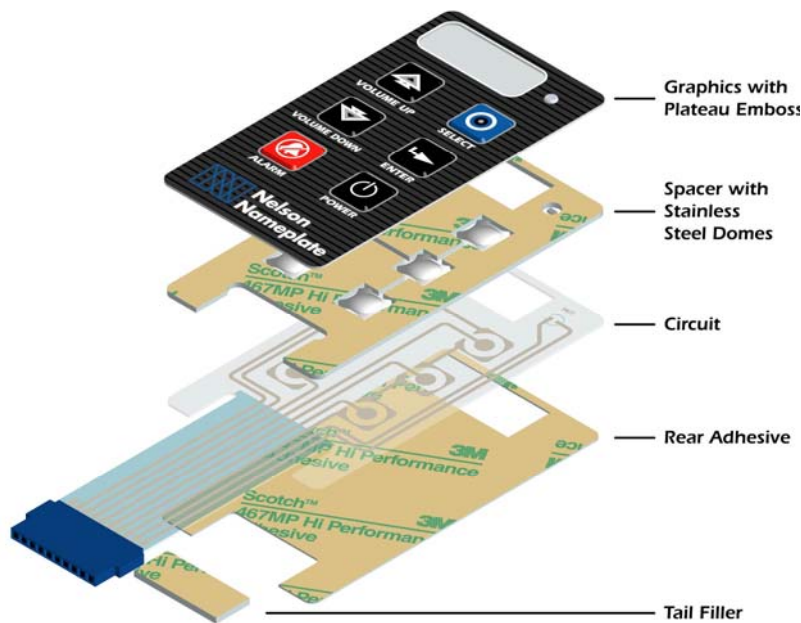

- If the embossing shape is larger than the dome retainer opening, or if a round or elliptical embossing is desired, a dome cover may be required to keep the dome in place.

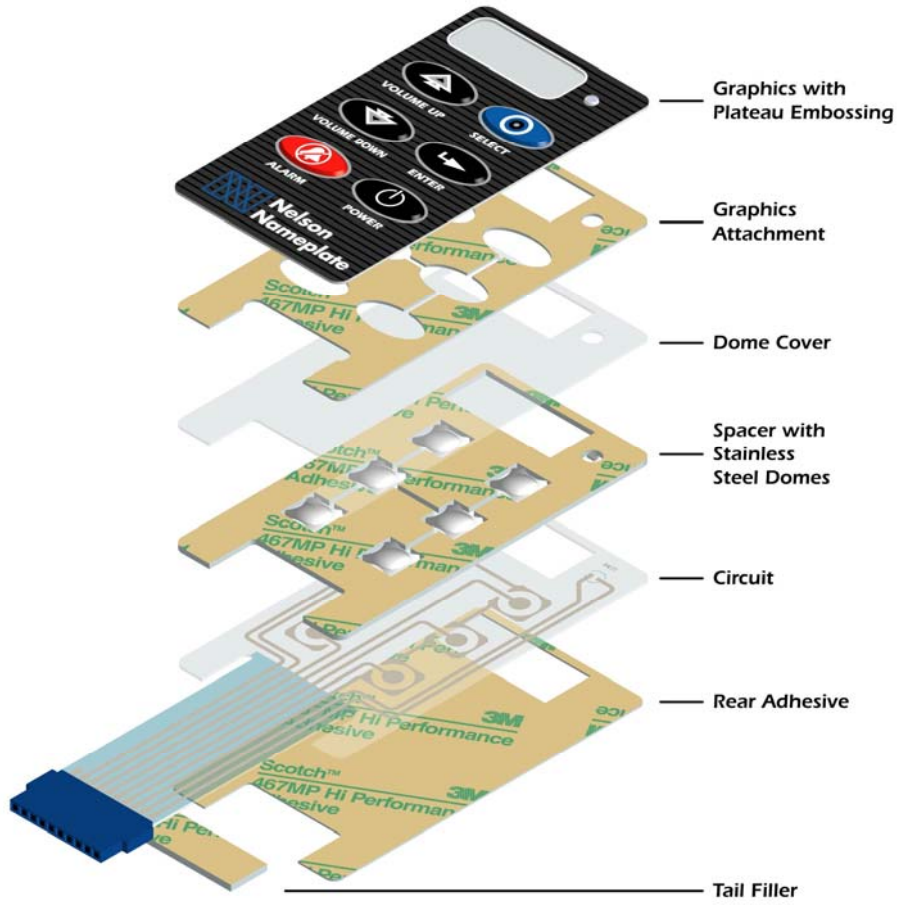

- Two circuit design:
  - A two circuit design has advantages, particularly when shielding is necessary. If a matrix designed schematic is needed, this may also prove to be the more advantageous design.

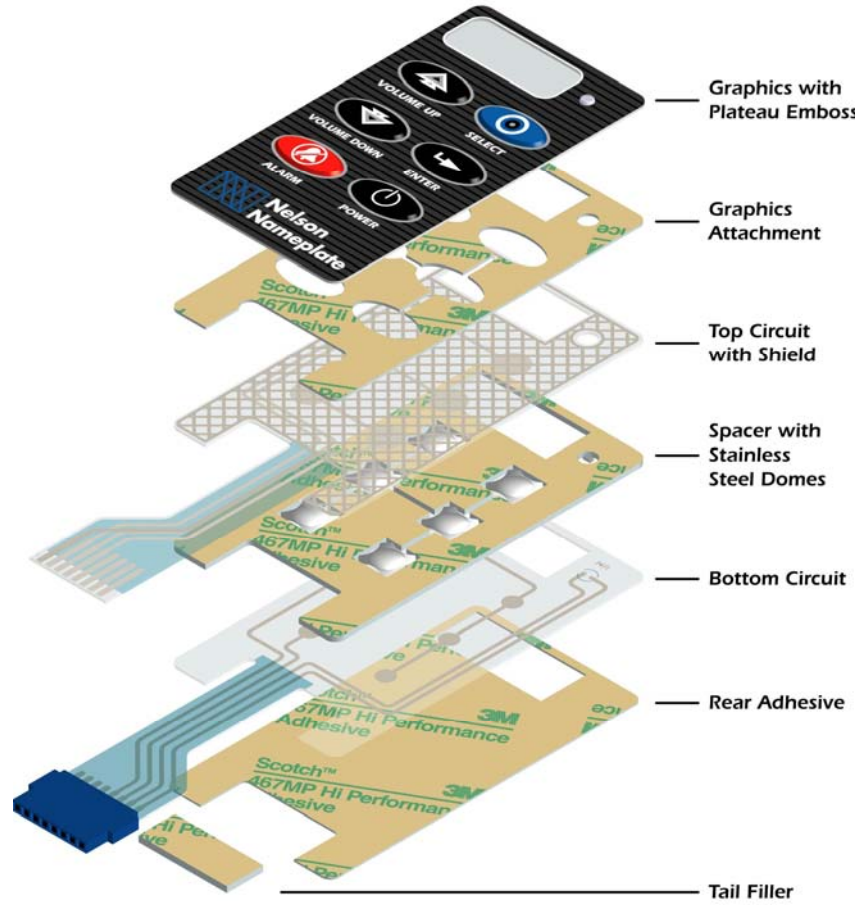

o Polydome Construction

- For orders over 1500 domes (i.e., the total number of domes per order, not per part) this design will often be more cost effective depending on the size of the part and the density of the domes.
- Tools are typically \$800-\$1200 for the hydroforming die alone.
- The tactile feel in this construction comes from the domes that are hydroformed in the top circuit layer.

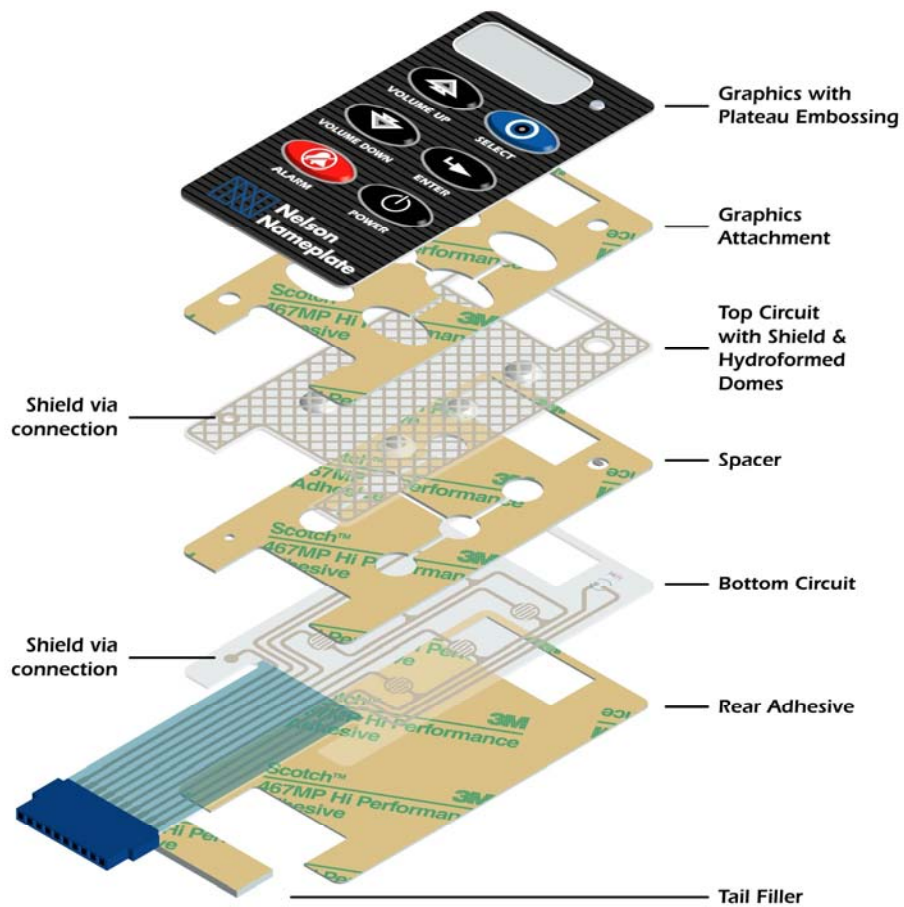

NELSON NAMEPLATE COMPANY  
OVERLAY MATERIAL GUIDE  
APPENDIX "B" OF THE MEMBRANE SWITCH DESIGN GUIDE

This chart reflects standard materials that are in Nelson's Material Selector.

<b><u>Material</u></b>	<b><u>Recommended for Outdoor Use</u></b>	<b><u>Base Film</u></b>	<b><u>Hardcoated</u></b>	<b><u>Finish</u></b>	<b><u>Embossable</u></b>	<b><u>U.L. Rating</u></b>	<b><u>Textureable</u></b>	<b><u>Thickness</u></b>
Melinex 561	No	Polyester	No	Gloss	Yes	No Rating	Yes	.003" - .010"
Autotex2-V	No	Polyester	Yes	Velvet	Yes	94HB*	Yes	.006" - .010"
Autotex2-V-UV	Yes	Polyester	Yes	Velvet	Yes	94HB*	Yes	.006" - .010"
Autoflex EBG	No	Polyester	Yes	Gloss	Yes	94HB*	Yes	.005" - .010"
Autoflex EBA	No	Polyester	Yes	Matte	Yes	94HB*	Yes	.005" - .010"
Autotex XE	Yes	Polyester	Yes	Velvet	Yes	94VTM-2	Yes	.008"
8010 Lexan	No	Polycarbonate	No	Gloss	Yes	94VTM-2	Yes	.007" - .030"
8B35 Lexan	No	Polycarbonate	No	Velvet	Yes	94VTM-2	Yes	.005" - .020"
HP-92 Lexan	No	Polycarbonate	Yes	Gloss	No	94HB	Yes	.007" - .030"
HP-40 Lexan	No	Polycarbonate	Yes	Matte	No	94HB	Yes	.007" - .030"
HP-12 Lexan	No	Polycarbonate	Yes	Matte	No	94HB	Yes	.007" - .030"
FR-60 Lexan	No	Polycarbonate	No	Gloss	Yes	94-V0	No	.010" - .040"
FR-65 Lexan	No	Polycarbonate	No	Velvet	Yes	94-V0	No	.010" - .020"
Makrofol EPC	Yes	Tedlar/Polycarbonate or Polyester	No	Velvet	Yes	94VTM-0	No	.010" - .030"
Marnot XL	No	Polycarbonate or Polyester	Yes	Various	Yes	94-V2	Yes	.007" - .030"

\* The UL Rating is recorded on the base material. Please view "UL Information for Autotype Industrial Films" located at [www.nelsonusa.com](http://www.nelsonusa.com).

Appendix C – Sample Drawing

REVISONS

REV	DESCRIPTION	DATE	APPROVED
A	PRODUCTION RELEASE	1/17/90	

COLOR TABLE

CODE	PANTONE NO.
Ⓐ	PROCESS BLACK C
Ⓑ	DARK GRAY 445C
Ⓒ	RED 186C
Ⓓ	OFF WHITE 427C
Ⓔ	DARK GRAY 445C - DEAD FRONT

NOTES UNLESS OTHERWISE SPECIFIED:

- OVERLAY MAT'L: 7 MIL THK POLYESTER
- ENTIRE OVERLAY SURFACE TO BE COATED WITH A SOLVENT RESISTANT VELVET TEXTURED HARDCOAT, EXCEPT LARGE DISPLAY WINDOW.
- ARTWORK FOR TARGET LOGO AND SYMBOL TO BE SUPPLIED BY TARGET, NO. A123.
- 0.090 HIGH HELVETICA, 4 PLACES.
- 0.280 HIGH HELVETICA MEDIUM, 12 PLACES.
- KEYS ARE TO BE PILLOW EMBOSSED 0.012/0.015 HIGH, 14 PLACES.
- LED WINDOW TO BE CLEAR WITH VELVET HARDCOAT.
- SWITCHES TO HAVE TACTILE FEEDBACK WHEN PRESSED.
- MOUNT MEMBRANE SWITCH TO SUPPORT PANEL USING 3M 467MP ADHESIVE.
- MAXIMUM LOOP RESISTANCE: 100 OHMS.
- MEMBRANE SWITCH TO BE INTERNALLY VENTED.
- CONNECTOR TYPE: BERG 65801-008 OR EQUIV.
- REFER TO SHEET 3 OF 3 FOR SUPPORT PANEL MECHANICAL INFORMATION.
- SOURCE OF SUPPLY: NELSON ENGINEERED GRAPHICS

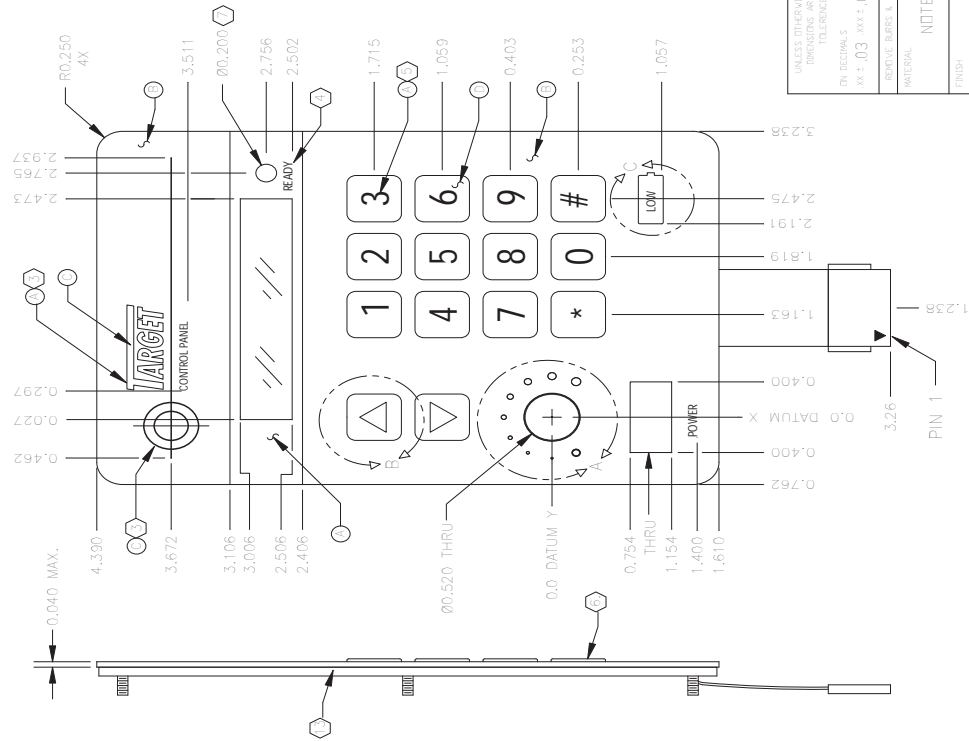

		8550 CANTERBURY AVENUE LOS ANGELES, CA 90039 (323) 463-3771	
APPROVALS	DATE	TITLE	
DESIGN		MEMBRANE SWITCH	
ENGINEER		SIZE	DWG. NO.
DRAW		B	
FINISH		SCALE	FILE NAME
NOTED			SAMPLE1.DWG
NOTED		SPEC-100	
DO NOT SCALE DRAWING		SHEET 1 OF 3	

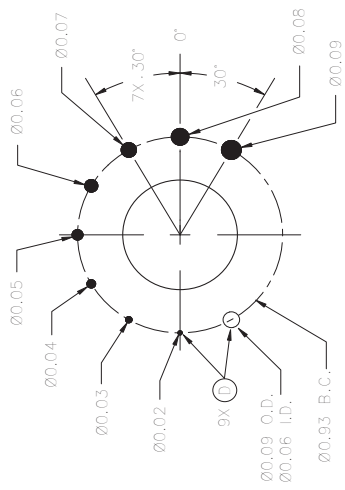

DETAIL A  
SCALE: 2:1

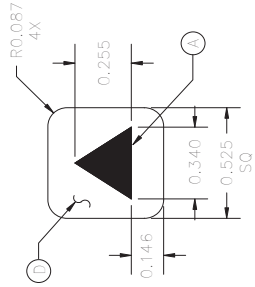

DETAIL B  
SCALE: 2:1

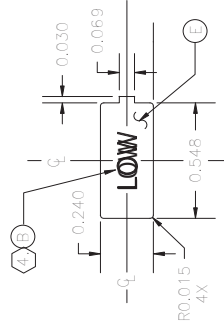

DETAIL C  
SCALE: 2:1

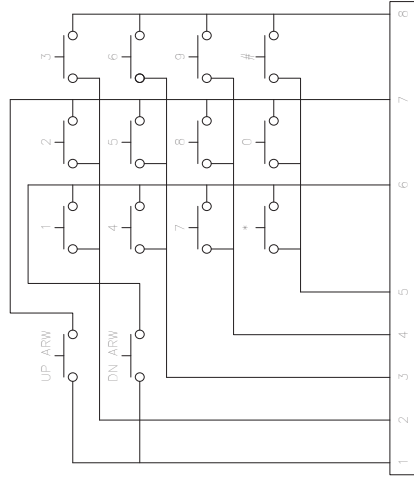

SCHEMATIC DIAGRAM

		2000 DASTICE AVENUE BOULDER, CO 80509 (303) 440-3973	
UNLESS OTHERWISE SPECIFIED DIMENSIONS ARE IN INCHES TOLERANCES ARE: DIM DECIMALS XX ± .03 XXX ± .015 ± 1/2°		TITLE MEMBRANE DETAILS AND SCHEMATIC	
APPROVALS DRAWN CHECKED ENGR MGR	DATE	SIZE B	INCHES SPEC-100
DO NOT SCALE DRAWING		SCALE N/A	SHEET 2 OF 3



NELSON NAMEPLATE COMPANY  
MEMBRANE SWITCH CHECK LIST  
APPENDIX "D" OF THE MEMBRANE SWITCH DESIGN GUIDE

The following items should be communicated to Nelson before an order is processed.

Mechanical dimensions of the finished part

Tolerance specified (+/- .015")

Type of switch

- Non Tactile
- Tactile Graphics
- Tactile with stainless steel domes
- Tactile with poly domes on the Circuit

Tail exit point

Tail length

Tail termination

- Exposed Silver/Carbon for ZIF
- Nicomatic
- Berg Clincher
- AMP
- Solder Tabs
- Other \_\_\_\_\_

Pinout

- Determined by Nelson
- Customer Specified

Shielding

- None required
- Aluminum foil
- Printed carbon
- Printed silver
- Other \_\_\_\_\_

Overlay material

- Nelson to determine best fit for application
- Polyester
- Polycarbonate
- Other \_\_\_\_\_

Logos and special graphics

- Customer supplied
- None required

Windows/Lens coating (See Nelson Window Design Guide)

- Velvet textured (enunciator, LED)
- Anti Glare (LED, VF, LCD)
- Gloss, water clear (LCD)

Window insert

Embossing

Key rims

Plateau

LED windows

Hydroforming

Key rims

Plateau

LED windows

Insertable legends

Not required

Specified

Support panel

Not required

Drawing included with material specified

Artwork

Nelson generated

Customer supplied (attached to order)

Colors specified

Color matching

Custom (samples supplied)

Pantone Matching System

Federal Standard No. 595a

Copy size, style, and location specified

Switch sealing requirements

Standard splash resistant

Specific Requirement \_\_\_\_\_

Switch venting requirements

Standard internal venting

Externally vented (For altitude and other uses)

Environmental and User considerations

Indoor, ambient environment

Indoor, High Moisture environment

Outdoor Protected

Outdoor Unprotected – Low Sun Exposure

Outdoor Unprotected – High Sun Exposure

NELSON NAMEPLATE COMPANY  
REQUEST FOR QUOTATION WORK SHEET  
APPENDIX "D" OF THE MEMBRANE SWITCH DESIGN GUIDE

Date \_\_\_\_\_ Part Number \_\_\_\_\_ Target Price \_\_\_\_\_  
Name \_\_\_\_\_ Title \_\_\_\_\_  
Company \_\_\_\_\_  
Address \_\_\_\_\_  
City \_\_\_\_\_ State \_\_\_\_\_ Zip \_\_\_\_\_  
E-Mail \_\_\_\_\_  
Phone \_\_\_\_\_ Ext. \_\_\_\_\_ Fax \_\_\_\_\_

Quote Quantities \_\_\_\_\_, \_\_\_\_\_, \_\_\_\_\_, \_\_\_\_\_, \_\_\_\_\_, \_\_\_\_\_

1. Overlay material (Polyester) \_\_\_\_\_
2. Number of colors on the overlay \_\_\_\_\_
3. Number of hardcoats on the overlay \_\_\_\_\_
4. Size of part \_\_\_\_\_ X \_\_\_\_\_
5. Size of gloss window \_\_\_\_\_ X \_\_\_\_\_
6. Number of windows \_\_\_\_\_
7. Number of cutouts \_\_\_\_\_
8. Hydroforming (Y/N) \_\_\_\_\_
9. Embossing (Y/N) \_\_\_\_\_
10. Number of switches with polydomes \_\_\_\_\_
11. Number of switches with stainless steel domes \_\_\_\_\_
12. Number of non-tactile switches \_\_\_\_\_
13. Matrix or Common Bus Schematic? \_\_\_\_\_
14. Tail length \_\_\_\_\_
15. Shielding (Y/N) \_\_\_\_\_
16. Rear adhesive (467MP or Specialty) \_\_\_\_\_
17. Subpanel (Y/N) \_\_\_\_\_
18. Connector type (Male/Female/ZIF) \_\_\_\_\_
19. Number of LEDs \_\_\_\_\_
20. Environment Switch will be used \_\_\_\_\_
21. Other requirements \_\_\_\_\_

\_\_\_\_\_  
\_\_\_\_\_