



Nelson Nameplate

Reference Testing: Polyester Dome Two Circuit

TECHNICAL DATA SHEET

MAY 2000

Life Cycle Testing

Life Cycle Testing Data

Selected switch positions are cycled for a total of ten million (10,000,000) cycles. Actuation force and closure resistance are measured per ASTM F 1597-95 *Standard Test Method for Determining the Actuation Force and Contact Force of a Membrane Switch* and ASTM F 1680-96 *Standard Test Method for Determining Circuit Resistance of a Membrane Switch*. The condition of the graphic overlay is also measured and is recorded periodically.

Life Cycle Test Results

Key #1 was tested. Closure resistance remained at 7.1 +/-0.3 ohms throughout the test. The maximum actuation force varied during the test with a high of 358 grams and a low of 293 grams. The initial value was 372 grams and final value was 362 grams. The key showed slight ink delamination in the center of the dome approximately 3/32" in size after 250,820 cycles. The area increased to approximately 1/8" after 539,067 cycles and remained that way until a portion of the graphic ink broke free after 1,500,000 cycles. After 4,000,000 cycles the area had increased to approximately 7/32" diameter and the area free from ink measured approximately 3/32" across. There were no significant changes until 8,000,000 cycles when the ink around the bottom edge of the spacer cavity began to delaminate. There were no significant changes for the remainder of the test.

Environmental Testing

Environmental Testing Procedure

Common circuits are connected together with a 35 VDC potential applied across the open contact through 18K-ohm current limiting resistors. The switches are subjected to temperature and humidity per ASTM 1596-95 Level 2 *Standard Practice for Exposure of Membrane Switches to Temperature and Relative Humidity*. Pretest and posttest measurements were taken of the switch travel, actuation force, contact force, circuit resistance, and the insulation resistance. Each of these measurements has a corresponding ASTM standard that was used in determining the results of the tests.

Environmental Test Results

Initial insulation resistance readings were all greater than 1×10^{11} ohms. After the ten day exposure to temperature and humidity per ASTM 1596-95 Level 2, all readings were greater than 3.6×10^{10} ohms. There was no silver migration. All other parameters remained virtually unchanged.

Construction Detail

See Construction Graphic B for construction detail.

For Additional Data

Please contact us to discuss your potential application needs or to receive detailed test data.

Nelson Nameplate Company

2800 Casitas Ave.

Los Angeles, CA 90039-2942

323/663-3971 Phone

323/661-2137 Fax

Or visit us on the Web at www.nelsonUSA.com

| | | | |
|------|--|------|----------|
| REV. | | DATE | APPROVED |
|------|--|------|----------|

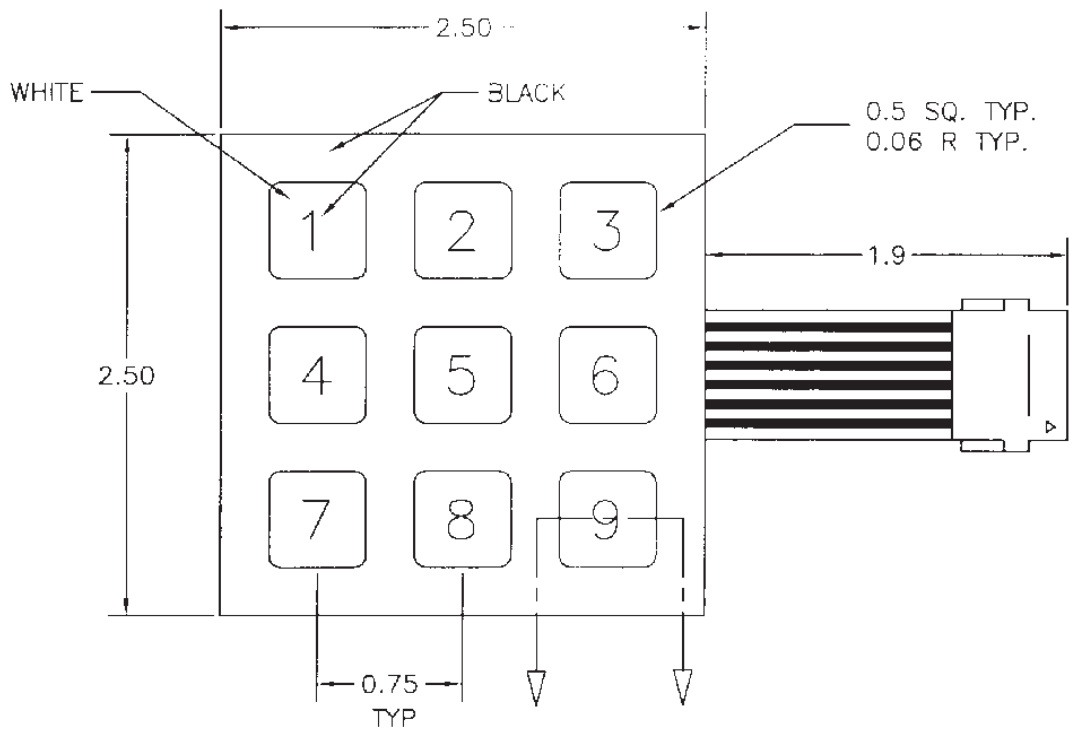

| CIRCUIT DETAIL MODIFIER | |
|-------------------------|----------------------|
| 1 | EXTERNALLY VENTED |
| 2 | CROSSOVERS |
| 3 | BIFURCATED W/ SHUNTS |

1. .006 AUTOTEX 2 V6 (OVERLAY)
2. .002 3M 467 (GRAPHICS ADHESIVE)
3. .010 8010 LEXAN (DOME SPACER)
4. .002 3M 467 (DOME SPACER ADHESIVE)
5. .005 ICI MELINEX 561 POLYESTER (TOP CIRCUIT)
6. .006 3M 7956 (CIRCUIT SPACER)
7. .005 ICI MELINEX 561 POLYESTER (BOTTOM CIRCUIT)
8. .002 3M 7952 (REAR ADHESIVE)
9. .0003 725A (SILVER INK)
10. HY.TECH POLYDOME NO. L-19 (.030 HIGH)

NOTE: DEFAULT DESIGN USES INTERNAL VENTING, NO CROSSOVERS.

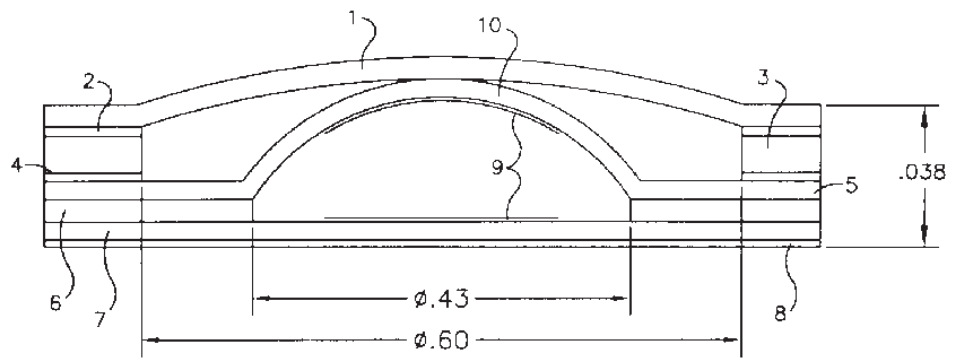

| | | | | |
|---|------------------|--------|---|---|
| UNLESS OTHERWISE SPECIFIED DIMENSIONS ARE IN INCHES TOLERANCES ARE: FRACTIONS DECIMALS ANGLES .XX = ±.010 .XXX = ±.005 | APPROVALS | DATE |  2800 CASITAS AVENUE LOS ANGELES, CA 90039 (323) 663-3971 | |
| | DRAWN SHANE MAST | 8/9/99 | | TEST SAMPLE CONSTRUCTION - B - POLY DOME - TACTILE SWITCH |
| | CHECKED | | SIZE A | |
| | MATERIAL | | | |
| FINISH | | | FILE # TESTCONS.DWG | |
| DO NOT SCALE DRAWING | | | SHEET 1 OF 1 | |